

KOMATSU

WD600-6R



Photos may show equipments not available in your area

Wheel dozer

Engine power
396 kW / 530 HP @ 1800 rpm

Operating weight
48090 - 49105 kg

Blade capacity
8.0 - 10.6 m³

Walk-around

Excellent operator environment

- Automatic transmission with Electronic Controlled Modulation Valve
- Low-noise design cab
- Modulated clutch system
- Engine RPM set system with auto decel
- Electronic Pilot Control mono lever
- Pillar-less large ROPS/FOPS (ISO 3471/ISO 3449) integrated cab
- Easy entry/exit, front-hinged door
- Advanced Joystick Steering System

High productivity & low fuel consumption

- High performance Komatsu SAA6D170E-5 engine
- Low fuel consumption
- Dual-mode engine power select system
- Variable traction control system
- Lock-up torque converter
- Variable displacement piston pump & Closed-center Load Sensing System (CLSS)
- Long wheelbase



Engine power
396 kW / 530 HP @ 1800 rpm

Operating weight
48090 - 49105 kg

Blade capacity
8.0 - 10.6 m³

Reliability

- Reliable Komatsu designed and manufactured components
- Sturdy main frame
- Adjustment-free, fully hydraulic, wet disc service and parking brakes
- Hydraulic hoses use flat face O-ring seals
- Cation electrodeposition process is used to apply primer paint
- Powder coating process is used to apply main structure paint
- Weatherproof connectors for electrical connections



Easy maintenance

- Equipment Management Monitoring System
- Komtrax Plus (optional)
- Ease of radiator cleaning
- Modular radiator core system

Harmony with environment

- EPA Tier 2 and EU Stage 2 emissions equivalent
- Low exterior noise
- Low fuel consumption

High productivity and low fuel consumption

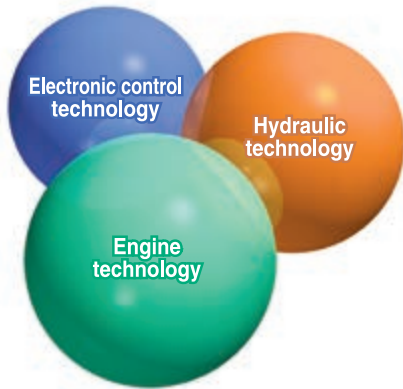

High performance Komatsu SAA6D170E-5 engine

Electronic heavy duty common rail fuel injection system provides optimum combustion of fuel. This system also provides fast throttle response to match the machine's powerful tractive effort and fast hydraulic response.
Net: 393 kW / 527 HP

Low fuel consumption

The fuel consumption is reduced greatly because of the low-noise, high-torque engine and the large-capacity torque converter with maximum efficiency in the low-speed range.

Dual-mode engine power select system

This wheel dozer offers two selectable operating modes, E and P. The operator can adjust the machine's performance with the selection switch.

E Mode: Provides maximum fuel efficiency for general dozing.

P Mode: Provides maximum power output for hard dozing operation or hill climb.

Variable traction control system

In limited traction situations where the operator would like to avoid tire slippage (such as sandy or muddy ground operation), operator can reduce slippage by activating the variable traction control system. The optimum rim pull (F1) is controlled by adjusting control knob from 100% to 20%.

Dual mode engine power selection switch



Variable Traction Control System knob

Lock up clutch switch

Lock-up torque converter

The Komatsu designed lock-up torque converter provides increased production efficiency, reduced cycle times and optimum fuel savings in hill-climb operations. This optional feature allows the operator to activate the system on/off with a switch located on the right-side control panel. Variable displacement piston pump & CLSS new design variable displacement piston pump combined with the CLSS delivers hydraulic flow just as the job requires preventing wasted hydraulic pressure. Minimized waste loss contributes to better fuel economy.

Variable displacement piston pump

The pump delivers hydraulic pressure only when required.

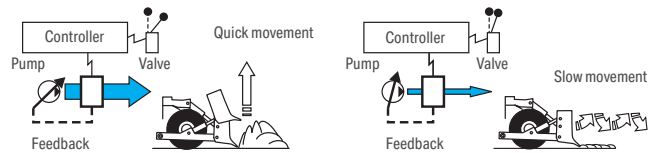

Fixed displacement piston pump

The pump delivers the maximum amount at any time. The unused flow is disposed of.

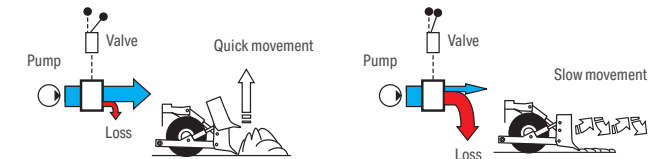

Durable blade

Komatsu blades are manufactured using high-tensile strength steel providing excellent rigidity and increased dozing capacity.

Blade capacities: 8.0 - 10.6 m³

Built-in blade tilt piping

Blade piping is built into the straight frame to protect it from damage.



Reliability

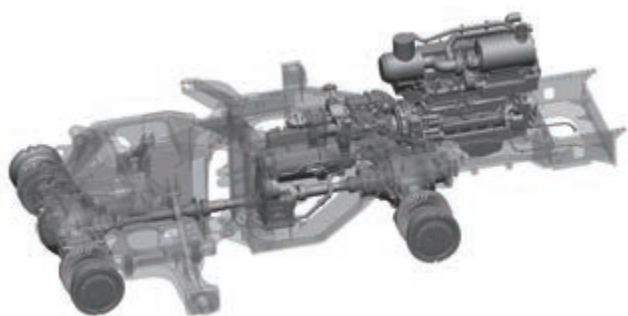

Komatsu components

Komatsu manufactures the engine, torque converter, transmission, hydraulic units, electric parts, on this wheel dozer. Komatsu dozers are manufactured with an integrated production system under a strict quality control system.

Wet multiple-disc brakes and fully hydraulic braking system

This means lower maintenance costs and high reliability. Wet multiple-disc brakes are fully sealed. Contaminants are kept out, reducing wear and maintenance. Brakes require no adjustments for wear. The new parking brake is also an adjustment-free, wet multiple-disc for high reliability and long life. Added reliability is designed into the braking system by the use of two independent hydraulic circuits. Provides hydraulic backup should one of the circuits fail.

Easy maintenance

Equipment Management Monitoring System

Monitor is mounted in front of the operator for easy viewing, allowing the operator to easily check gauges and warning lights.

Maintenance control and troubleshooting functions

- Action code display function: If abnormality occurs, the monitor displays action details on the character display at the bottom center of the monitor.
- Monitor function: Controller monitors engine oil level, pressure, coolant temperature, air cleaner clogging, etc. If controller finds abnormalities, the error is displayed on Liquid Crystal Display (LCD).
- Replacement time notice function: Monitor informs replacement time of oil and filters on LCD when replacement intervals are reached.
- Trouble data memory function: Monitor stores abnormalities for effective troubleshooting.

Modular radiator core system

The modular radiator core is easy to replace without removing the entire radiator assembly.

High-rigidity frames

Front and rear frames are designed to work in the toughest applications and provide high rigidity for the power train and dozer equipment. The high-rigidity frames, together with the reinforced dozer linkage, reduce dozing stress and shock.

Limited slip differential (F & R) (optional)

The field-proven limited slip differential prevents tire slippage on slippery terrain such as soft or sandy ground, so stable travel is ensured and tire wear is reduced to a minimum for maximum tire life.

Flat face-to-face O-ring seals

Flat face-to-face O-ring seals are used to securely seal hydraulic hose connections and to prevent oil leakage. In addition, buffer rings are installed to the head side of the all-hydraulic cylinders to lower the load on the rod seals and maximize the reliability.

Weatherproof connectors

Main harnesses and controller connectors are equipped with weatherproof connectors providing high reliability, dust and corrosion resistance.

Cation electrodeposition primer paint/powder coating final paint

Ease of radiator cleaning

If the machine is operating in adverse conditions, the operator can reverse the hydraulic cooling fan from inside the cab by turning a switch on the control panel.

KOMTRAX Plus (optional)

Komtrax Plus is a management system for large mining equipment, which enables detailed monitoring of the fleet via satellite. Komatsu and distributors can analyze "vehicle health", other operating conditions and provide this information to the job site, using the Internet from a remote location, on a near-real time basis. As a result, customers receive timely vehicle maintenance, reduced maintenance expenses, downtime costs and avoid mechanical trouble.

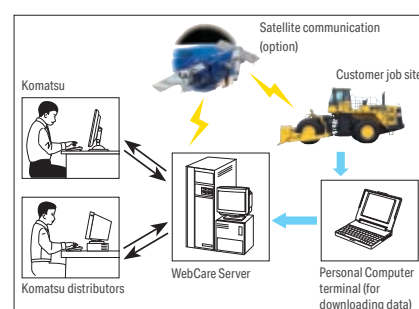

Operator environment

Easy operation

Automatic transmission with Electronically Controlled Modulation Valve

Automatic transmission with Electronically Controlled Modulation Valve automatically selects the proper gear speed based on travel speed, engine speed, and other travel conditions. The electronically controlled modulation Valve engages the clutch smoothly to help prevent lag and shock when shifting. This system provides efficient machine operation for a comfortable ride.

Kick-down switch: Consider this valuable feature for added productivity. With the touch of a finger, the kick-down switch automatically downshifts from second to first when beginning the dozing. It automatically upshifts from first to second when the direction control lever is placed in reverse.

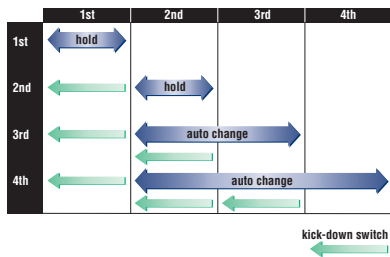

This results in increased rim pull for better blade penetration and reduced cycle times for higher productivity.

Hold switch: Auto shift is selected and if the operator turns on this switch when the lever is at the 3rd or 4th gear speed position, the transmission is fixed to that gear speed.

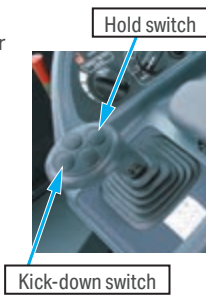

Modulated clutch system

The modulated clutch system controls the tractive effort with left brake pedal from 100% to 20% of the converter output torque.

- Useful for smooth speed reduction when approaching the end of dozing
- Easy control of tire slippage
- Reduction of shocks in shifting from forward to reverse

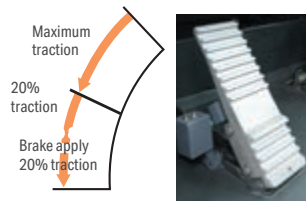

Optional equipment

Steering wheel with telescopic/tilt column

As an alternative to the Advanced Joystick Steering System, a steering wheel is also available. The operator can tilt and telescope the steering column to provide a comfortable working position.

Electronic controlled transmission lever

Change direction or shift gears with a touch of a finger without removing the shifting hand from the steering wheel. Solid state electronics and conveniently located direction and gear shift controls make this possible. Automatic shifts in ranges 2 to 4 keep production high and manual shifting at a minimum.

Electronic pilot control mono lever

The finger control electronic pilot control work equipment lever has light operating effort and short stroke facilitating easy operation. The operator's comfort is further increased by the full large size adjustable arm rests. Combined with CLSS, this system allows the following new functions for easy and efficient operation:

Advanced Joystick Steering System

Advanced Joystick Steering System is a feedback steering system which has been incorporated to allow steering and forward and reverse selection to be controlled by wrist and finger control. With the feedback function added, the machine steering angle is defined exactly the same angle as the lever tilt angle.

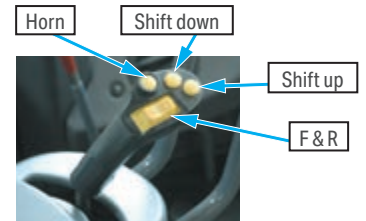

Comfortable operation



Low-noise design

Noise at operator's ear noise level (ISO 6396:2008):

76 dB(A)

Dynamic noise level (outside) (ISO 6395:2008): 113 dB(A)

Pillar-less darge cab

A wide pillar-less flat glass provides excellent front visibility. The wiper arm covers a large area to provide great visibility even on rainy days. The cab area is the largest in its class providing maximum space for the operator.



Specifications



Engine

ModelKomatsu SAA6D170E-5
 Type Water-cooled, 4-cycle
 Aspiration Turbocharged, aftercooled
 Number of cylinders 6
 Bore × stroke 170 mm × 170 mm
 Piston displacement 23.15 l
 Governor All-speed, electronic
 Horsepower
 SAE J1995 Gross 396 kW / 530 HP
 ISO 9249/SAE J1349* Net 393 kW / 527 HP
 Rated rpm 1800 rpm
 Fan drive method for radiator cooling Hydraulic
 Fuel system Direct injection
 Lubrication system:
 Method Gear pump, force-lubrication
 Filter Full-flow type
 Air cleaner Dry type with double elements and dust evacuator,
 plus dust indicator

* Net horsepower at the maximum speed of radiator cooling fan is 374 kW / 502 HP.
 EPA Tier 2 and EU Stage 2 emissions equivalent.



Transmission

Torque converter:
 Type 3-element, single-stage, double-phase
 Transmission:
 Type Full-powershift, planetary type
 Travel speed: km/h
 Measured with 35/65-33 tires
 () : Look-up clutch ON

	1st	2nd	3rd	4th
Forward	6.7	11.7	20.3	33.0
	—	(12.4)	(21.7)	(37.7)
Reverse	7.3	12.8	22.0	36.0



Axles and final drives

Drive system Four-wheel drive
 Front Fixed, full-floating
 Rear Center-pin support, full-floating, 26° total oscillation
 Reduction gear Spiral bevel gear
 Differential gear Conventional type
 Final reduction gear Planetary gear, single reduction



Brakes

Service brakes Hydraulically actuated,
 wet multiple-disc brakes actuate on four wheels
 Parking brake Wet multiple-disc brake
 Secondary brake Parking brake is commonly used



Steering system

Type Articulated type, full-hydraulic power steering
 Steering angle 43° each direction
 Minimum turning radius at
 the center of outside tire 7075 mm



Hydraulic system

Steering control:
 Hydraulic pump Piston pump
 Capacity 163 l/min at rated rpm
 Relief valve setting 34.3 MPa / 350 kgf/cm²
 Hydraulic cylinders:
 Type Double-acting, piston type
 Number of cylinders 2
 Bore × stroke 130 mm × 510 mm
 Implement control:
 Hydraulic pump Piston pump
 Capacity 180 + 180 l/min at rated rpm
 Relief valve setting 24.5 MPa / 250 kgf/cm²
 Hydraulic cylinders:
 Type Double-acting, piston type
 Number of cylinders—bore × stroke:
 Blade lift 1- 160 mm × 1080 mm
 Tilt and pitch 2- 180 mm × 237 mm
 Control valve 3-spool type
 Control positions:
 Blade lift Raise, hold, lower, and float
 Tilt and pitch Tilt-left, tilt-right, hold, pitch forward and back
 Hydraulic cycle time
 Raise 2.0 s
 Lower 1.3 s
 Tilt (left / right) 0.8 / 1.1 s
 Pitch (front / rear) 2.1 / 1.6 s



Service refill capacities

Cooling system 147 l
 Fuel tank 718 l
 Engine 86 l
 Hydraulic system 443 l
 Axle (each front and rear) 155 l
 Torque converter and transmission 83 l



Dimensions

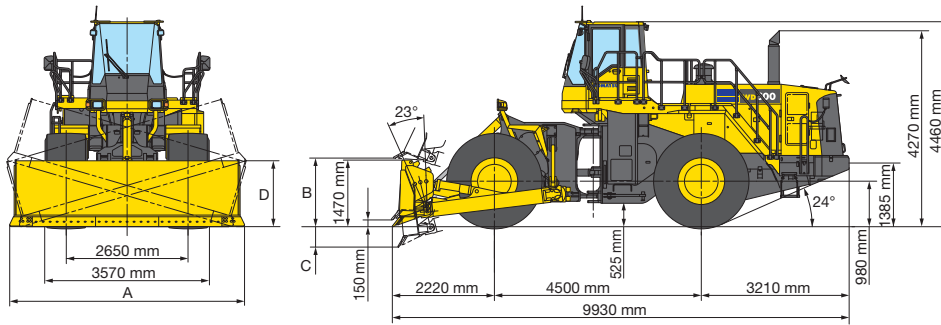

Measured with 35/65-33-24PR(L4) tires

Blade type		Straight blade	U-blade
Blade capacity (SAE rated)		8.0 m ³	10.6 m ³
A	Blade width	5100 mm	4870 mm
B	Max. lift above ground	1500 mm	1485 mm
C	Max. drop below ground	450 mm	490 mm
D	Max. tilt adjustment	1430 mm	1340 mm
Operating weight		48090 kg	49105 kg



Standard equipment

- 3-spool valve for raise, lower and pitch controls
- Advanced Joystick Steering System
- Alternator, 24 V/90 A
- Auto air conditioner
- Auto shift transmission with mode select system
- Back-up alarm
- Back-up lamp
- Batteries, 2 × 12 V/200 Ah
- Cap lock & cover lock
- Cigar lighter & ashtray
- Directional signal
- Electric supply, 12 V
- Engine, Komatsu SAA6D170E-5 diesel
- Engine RPM set
- Electronic Pilot Control fingertip control lever
- Floormat
- Front fender
- Hard water area arrangement (corrosion resistor)
- Hydraulic-driven fan with reverse rotation
- Lift cylinder, tilt and pitch cylinders
- Lock-up clutch torque converter
- Main monitor panel with Equipment Management Monitoring System
- PM service connector
- Radiator mask, lattice type
- Rear access stairs
- Rear defroster (electric)
- Rear under view mirror
- Rearview mirrors
- Rear window washer and wiper
- ROPS/FOPS (ISO 3471/ISO 3449) cab
- Seat belt
- Seat, suspension type with reclining
- Service brakes, wet disc type
- Standard counterweight
- Starter receptacle
- Starting motor, 2 × 24 V/11.0 kW
- Straight blade, 8.0 m³ with straight end bit
- Sun visor
- Tires (35/65-33-24PR L4 tubeless) and rims
- Transmission, 4 forward and 4 reverse



Optional equipment

- AM/FM radio
- AM/FM radio with cassette
- Battery disconnect switch
- Secondary steering (ISO 5010)
- Fire extinguisher
- Fuel quick coupler
- In line filter hydraulic
- In line filter steering
- Limited slip differential (F&R)
- Ordinary spare parts
- Power train guard
- Rear fender
- Steering wheel, tiltable
- Straight blade, 8.0 m³ with angle end bit
- Tool kit
- U-blade, 10.6 m³
- Komtrax Plus

Your Komatsu partner:

KOMATSU

komatsu.com