

KOMATSU

D85ESS-2A



Photos may show equipments not available in your area

Crawler dozer

Engine power
149 kW / 200 HP @ 1950 rpm

Operating weight
20670 kg

Blade capacity
3.4 - 6.8 m³

Walk-around

The Komatsu S6D125E-2 diesel engine

provides an output of 149 kW / 200 HP with excellent productivity.

Gull-wing engine side covers

for easy and safer servicing (option).

High capacity straight tilt dozer

combined the highest power in its class with outstanding productivity.

Blade tilt lines

completely protected.



Modular power train

for increased serviceability and durability.

Engine power

149 kW / 200 HP @ 1950 rpm

Operating weight

20670 kg

Blade capacity

3.4 - 6.8 m³

Electronic monitoring system

prevents minor problems from developing into major ones (option).

Left hand joystick

controls all tractor motion. Right hand joystick controls all blade movements.



Optional hexagonal, low noise cab

with viscous damping mounts provides unsurpassed operator comfort and visibility.



Bolt-on segmented sprocket teeth

for easy in-the-field replacement.

Wet, multiple-disc brakes

eliminates brake-band adjustments for maintenance-free operation.

Forward mounted pivot shafts

isolate final drives from blade loads.

Komatsu Torqflow transmission

offers single lever control of speed (3 forward and 3 reverse) and directional changes.

Operator's compartment

All steering, direction, and speed changes are made by a left-hand single joystick control. If the operator wants to move the machine forward and to the left, he simply moves the joystick forward and to the left. If he desires a gear change, he merely twists his wrist. The machine responds to the movement of the lever providing the operator with the feeling of natural control with Komatsu's joystick.

Low-noise design

For smoother riding comfort, power train components and hydraulic control valves are mounted to the frame with rubber pads to soften vibration and shut out noise. Since the D85ESS employs joysticks, the walk-through operator compartment is uncluttered for smooth entry and exit. An adjustable seat with backrest is standard equipment.

Three-stage height adjustable armrests

Three-stage height adjustable armrests and relocated fuel control lever provide comfortable operation and increased leg space.



Hexagonal pressurized cab (optional)

Air filters and a higher internal air pressure combine to prevent external dust from entering the cab. In addition, the cab's hexagonal design provides excellent front, side, and rear visibility. The viscous damper cab suspension softens shocks for operator comfort and extends component life.

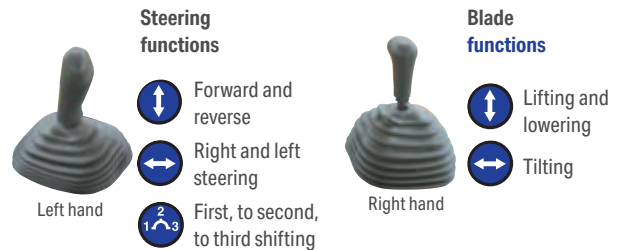

Easy-to-operate work equipment control lever

With the Closed-center Load Sensing (CLSS) hydraulic system, blade lever stroke is directly proportional with blade speed, regardless of the load and travel speed. This results in superb, fine controllability.

Benefits of CLSS

- More precise and responsive operation due to the pressure compensation valve.
- Reduced fuel consumption by discharging only the required amount of oil from the pump.
- The work equipment moves smoothly for operations such as side-cutting even when priority is given to steering.

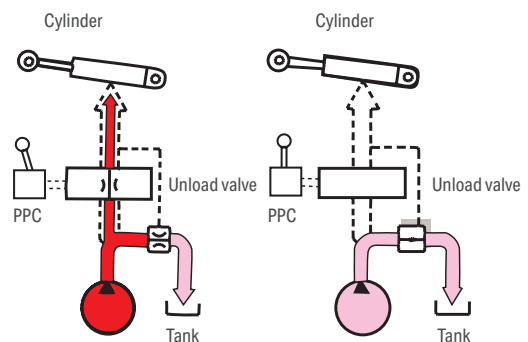

Electronic monitoring system (option)

An electronic monitoring system prevents minor problems from developing into major ones. All meters and gauges are controlled by a microcomputer, which provides a wide indication range for an easier, more precise reading.



Reliability features

Field-proven engine

Powerful S6D125E-2 diesel engine provides a massive output of 149 kW / 200 HP. The engine power is transmitted smoothly to the final drives via a high-efficiency torque converter.

Modular designed power train units

The modular design allows easy removal and installation of any individual unit for shorter downtime.

Flat bottom frame

A flat bottom frame, the monocoque track frames and forward-mounted pivot shafts provide good maneuverability in muddy terrain by preventing mud from building up under the frame.

Sturdy design

Because fewer components mean greater reliability, we've designed a simple hull frame made of a thick, single plate. Track frames have a large-section construction for maximum rigidity. Even the box-section construction of the blade back beam is reinforced, all with durability in mind.

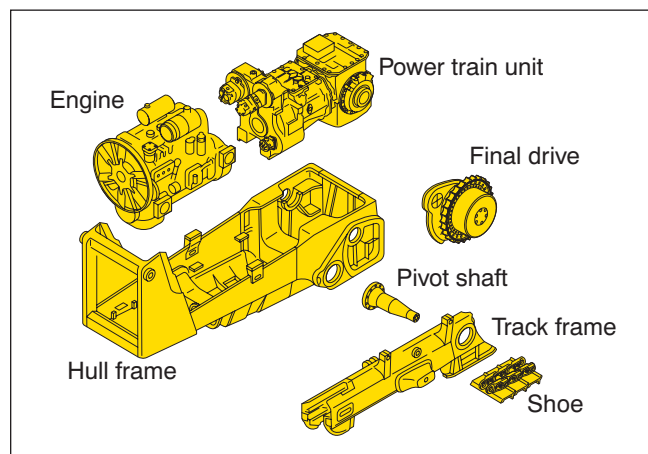

Tough undercarriage

Large-diameter bushings, increased track link heights, and improved oil-seals help to increase undercarriage durability. Serviceability has also been improved with the addition of remote greasing of the equalizer bar center pin.

Low drive and long track undercarriage

Komatsu's design is extraordinarily tough and offers excellent grading ability and stability.

Easy maintenance

Wet, multiple-disc brakes

Eliminate brake-band adjustments for maintenance-free operation.

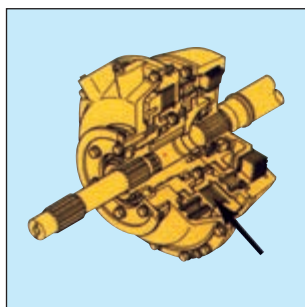

Oil pressure check ports (optional)

Oil pressure check ports for the power train are centralized on the right hand side of the operator platform for easy access.



Coolant reservoir

A radiator coolant reservoir makes it easier to check the coolant level and eliminates frequent refilling.



Gull-wing engine side covers (optional)

A gas-spring cylinder opens the gull-wing engine side covers widely, allowing the engine and auxiliary components to be easily checked.



Specifications



Engine

Model.....Komatsu S6D125E-2
 Type..... 4-stroke cycle, water-cooled, direct injection
 Aspiration..... Turbocharged
 Number of cylinders..... 6
 Bore x stroke..... 125 mm x 150 mm
 Piston displacement..... 11.04 l
 Governor..... All-speed, mechanical
 Horsepower
 ISO 9249 / SAE J1349.....Net 149 kW / 200 HP
 Rated rpm..... 1950 rpm
 Fan drive type..... Mechanical
 Lubrication system
 Method..... Gear pump, forced lubrication
 Filter..... Full-flow
 Net maximum torque..... 981 N•m / 100 kg•m @ 1200 rpm



Torqueflow transmission

Komatsu's TORQFLOW transmission consists of a water-cooled, 3-element, 1-stage, 1-phase torque converter and a planetary gear, multiple-disc clutch transmission which is hydraulically actuated and force-lubricated for optimum heat dissipation. Joystick control of gears (3 forward and 3 reverse) and directional steering changes. Gearshift lock lever and neutral safety switch prevent machine from accidental starts

Gear	Forward	Reverse
1st	0-3.9 km/h	0-5.0 km/h
2nd	0-6.8 km/h	0-8.6 km/h
3rd	0-10.6 km/h	0-13.4 km/h

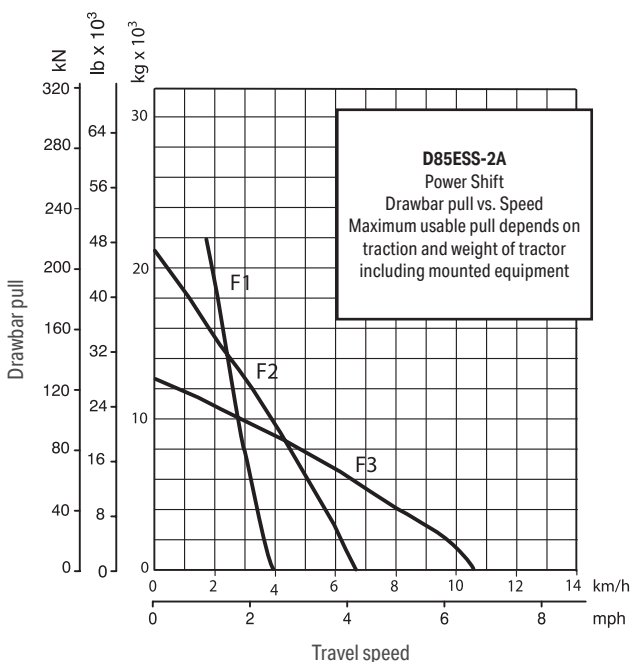

Final drives

Double-reduction final drives of spur gear and planetary gears to minimize transmission of shocks to power train components. Segmented sprocket are bolt-on for easy in-the-field replacement.



Steering system

Joystick controls for all directional movements. Pushing the joystick forward results in forward machine travel, while pulling it rearward reverses the machine. Simply tilt the joystick to the left to make a left turn. Tilt it to the right for a right turn.

Wet, multiple-disc steering clutches are hydraulically loaded and hydraulically released. Wet, multiple-disc brakes are spring-actuated and hydraulically released.

Steering brakes also function as service and parking brakes.

Minimum turning radius*: 3.4 m

*As measured by track marks on ground.



Undercarriage

Suspension..... Oscillation with equalizer bar and forward mounted pivot shafts
 Track roller frame..... Monocoque, large section, durable construction
 Track shoes..... Lubricated tracks. Unique dust seals for preventing entry of foreign abrasives into pin-to-bushing clearances for extended service. Track tension is easily adjusted with a grease gun.

Number of carrier rollers (each side)..... 2

Number of track rollers (each side)..... 8

Ground contact area..... 30400 cm²

Ground pressure..... 0.50 kg/cm²



Service refill capacities

Coolant..... 52 l

Fuel tank..... 406 l

Engine oil..... 38 l

Damper..... 1.7 l

Transmission, bevel gear, and steering system..... 48 l

Final drive (each side)..... 27 l



Operating weight

Tractor weight..... 15420 kg

Including rated capacity of lubricant, coolant, full fuel tank, operator and standard equipment.

Operating weight..... 20670 kg

Including angle dozer, multi-shank ripper, FRP canopy (optional), operator, standard equipment, and rated capacity of lubricants, coolant, and full fuel tank.

Hydraulic system

Closed-center load sensing system (CLSS) designed for precise and responsive control, and for efficient simultaneous operation.

Hydraulic control units:

All spool control valves externally mounted beside the hydraulic tank.

Type of pump: Gear pump

Capacity (discharge flow at rated engine rpm): 180 l/min

Relief valve setting 20.6 MPa / 210 kgf/cm²

Hydraulic cylinders Double-acting, piston

	No of cylinders	Bore
Blade lift	2	95 mm
Blade tilt	1	140 mm
Ripper lift	1	150 mm

Control valves:

Spool control valve for semi-U tilt dozer and straight tilt dozer.

Positions: Blade lift Raise, hold, lower, and float

Blade tilt Right, hold, and left

Spool control valve for angle dozer.

Positions: Blade lift Raise, hold, lower, and float

Additional control valve for multi-shank ripper

Positions: Ripper lift Raise, hold, and lower

Hydraulic oil capacity (refilling):

Straight tilt dozer 55 l

Angle tilt dozer 55 l

Multi-shank ripper 55 l

Dozer equipment

Use of high tensile strength steel in moldboard for strengthened blade construction.

	Overall length with blade	Blade capacity	Blade width × height	Max. lift above ground	Max. drop below ground	Max. tilt adjustment	Blade angle	Dozer equipment add. weight	Hyd. control unit add. weight
	mm	m ³	mm	mm	mm	mm	deg	kg	kg
Angle dozer	5930	3.4	4370 × 1070	1255	485	400	25	2890	540
Straight tilt dozer	5615	4.4	3620 × 1295	1070	590	460	-	2220	590
Semi-U tilt dozer	5770	6.8	3640 × 1565	1070	590	460	-	2520	590

Blade capacities are based on the SAE recommendation practice SAE J1265.

Dimensions

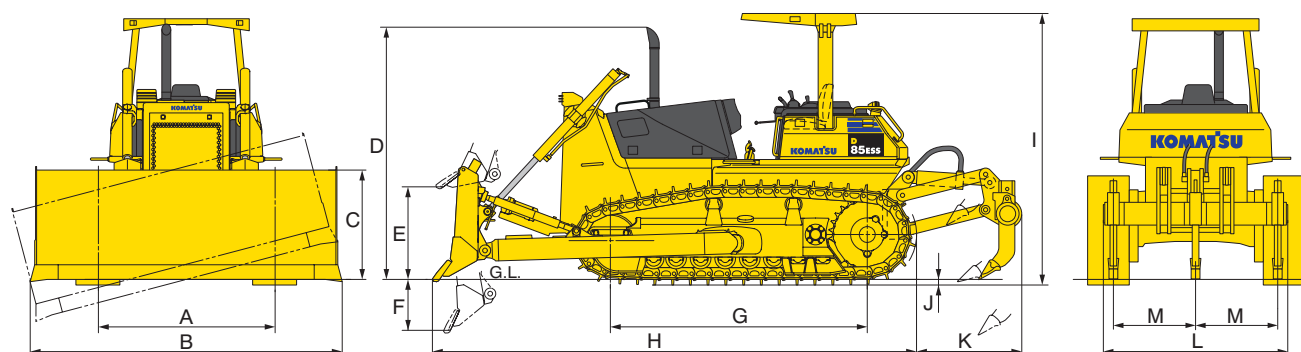

Ground clearance: 400 mm

Dimension with straight tilt dozer and multi-shank ripper.

A	2050 mm
B	3620 mm
C	1295 mm
D	2980 mm
E	1070 mm

F	590 mm
G	2980 mm
H	5615 mm
I	3160 mm
J	65 mm

K	1220 mm
L	2170 mm
M	950 mm



Standard equipment

- Air cleaner, double element with dust indicator
- Alternator, 35 A/24 V
- Batteries, 140 Ah/2 × 12 V
- Blower cooling fan
- Decelerator pedal
- Engine hood
- Fenders
- Lighting system, (includes 2 front, 1 rear)
- Mono-lever steering
- Muffler with curved exhaust pipe
- Radiator guard door, flat
- Radiator reserve tank
- Rear cover
- ROPS mounting brackets
- Starting motor, 7.5 kW/24 V
- Seat, adjustable
- Track roller guard, end sections
- Track shoe assembly
- Sealed and lubricated track
510 mm single grouser shoes
- Underguards, oil pan and transmission
- Wet, multiple-disc steering clutch/blake



Optional equipment

- Air conditioner
- Backup alarm
- Cab
- Cab accessories
 - Cup holder
 - Rear view mirror
- Cooling fan, reversible
- Electronic instrument monitor panel
- Engine side covers, gull-wing
- Front pull hook
- Heater and defroster
- Hitch type drawbar
- High mount foot rests
- Hydraulics for ripper
- Hydraulics for tilt dozer
- Intake pipe with precleaner
- Light working, cab additional
- Locks, filler caps and covers
- Pressure check ports for power train
- Radiator core protective grid
- Rigid type drawbar
- ROPS canopy
- ROPS canopy with sweep
- Seat belt, retractable
- Suspension seat, with high-back
- Suspension seat, reclining with fabric material (cab only)
- Track roller guard, full length
- Underguard, heavy-duty
- Vandalism protection cover for instrument panel
- Water separator

ROPS canopy

Meets ISO 3471 and SAE J1040 APR88, ROPS standards, and ISO 3449 FOPS standard.

Additional weight 420 kg

Roof dimensions:

Length 1830 mm

Width 1600 mm

Height from operator

compartment floor 1700 mm

Steel cab

All-weather, enclosed pressurized cab

Additional weight 285 kg

Dimensions:

Length 1765 mm

Width 1720 mm

Height 1625 mm

Height from floor to ceiling 1515 mm

Multi-shank ripper

Weight (including hydraulic control unit) . . . 1680 kg

Beam length 2170 mm

Maximum digging depth 595 mm

Maximum lift above ground 640 mm

ROPS canopy for cab

Meets ISO 3471 and SAE J1040 APR88, ROPS standards, and ISO 3449 FOPS standard.

Additional weight 340 kg

Roof dimensions:

Length 1270 mm

Width 1490 mm

Height from operator

compartment floor 1705 mm

Shoes

Type	Additional weight	Ground contact area
560 mm single grouser shoe	+120 kg	33380 cm ²
610 mm single grouser shoe	+230 kg	36360 cm ²
660 mm single grouser shoe	+360 kg	39340 cm ²

Your Komatsu partner:

KOMATSU

komatsu.com